



LIMA

SPEC SHEET

Lead Time: 4 - 6 weeks
Warranty: 10 years

Please refer to a physical sample. Images are for an indicative reference only.
Actual product may vary slightly, depending upon model configurations.

FEATURES

- » Supports up to 6.5kg in monitor weight
- » All in one box solution for a single screen set up
- » Additional arm available separately for dual screen (LMA/001/002)
- » Articulation range and smoothness of motion
- » Integral post clamp (clamp range 6 to 40mm)
- » Height adjustability achieved using push button technology
- » Fast and easy installation
- » 3-point cable management guides cables tidily from monitor to desktop
- » Material selection and 'design-for-disassembly' make Lima 100% recyclable at the end of its operational life.
- » Available in Black, White and Grey

SPECIFICATIONS

Max. Load:	6.5kg
Max. Height:	450mm
Max. Reach:	456mm
Vertical Range:	210mm
Tilt Range:	+80° / -10°
Max. Screen Size:	27" (Dual Screen)
Product Net Weight:	1.9kg
Monitor Head:	VESA 75 and 100 compliant
Desk Clamp Range:	6mm to 40mm

LIMA.

Please refer to a physical sample.
 Images are for an indicative reference only.
 Actual product may vary slightly, depending upon model configurations.

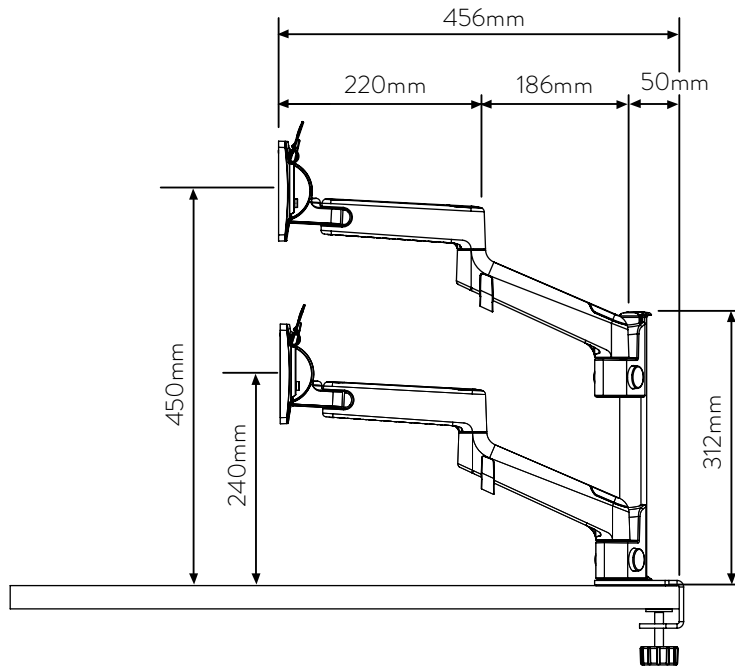

VESA TILT RANGE

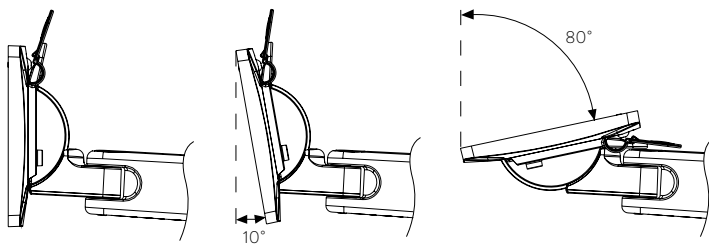

CLAMP DIMENSIONS

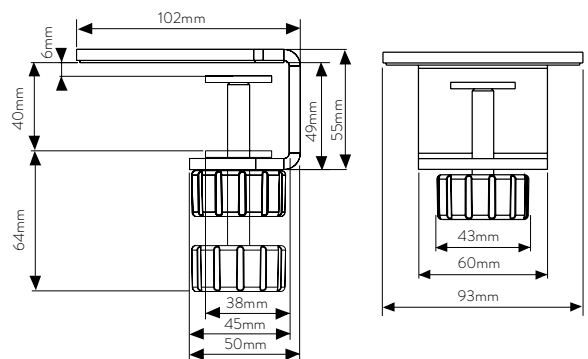

Watts Commercial Furniture

350a Edgar St
 Bankstown NSW 2200
 PO Box 275 Condell Park 2200
 ABN: 54 064 557 893

p: 02 9771 3966
 wcf.com.au
 sales.watts@wcf.com.au
 accounts.watts@wcf.com.au

Watts Commercial Furniture reserves the right to change any or all details without prior notice. Every effort has been made to ensure the information is accurate at the time of printing.

September 2022