

C.ME

SPEC SHEET

Lead Time: 4 - 6 weeks
Warranty: 7 years

Please refer to a physical sample. Images are for an indicative reference only.
Actual product may vary slightly, depending upon model configurations.

FEATURES

- » Supports up to 8kg in monitor weight
- » Available as a single arm, dual arm, triple arm, or quad arm support.
- » Bolt Through and Desk Clamp fittings both included.
 - Desk clamp range 18 to 33mm
 - Bolt through range 18 to 30mm
- » Height adjustability achieved using safe push button mechanism
- » Fast and easy installation
- » Integrated cable management
- » Available in Black and White

SPECIFICATIONS

Max. Load:	8kg
Max. Height:	465mm
Max. Reach:	445mm
Vertical Range:	330mm (Single Screen) 260mm (Dual Screen)
Tilt Range:	+135° / -40°
Max. Screen Size:	740mm (Dual Screen)
Monitor Head:	VESA 75 and 100 compliant
Desk Clamp Range:	18mm to 33mm
Bolt Through Range:	18mm to 30mm

C.ME.

Please refer to a physical sample.
 Images are for an indicative reference only.
 Actual product may vary slightly, depending upon model configurations.

STANDARD POST HEIGHT

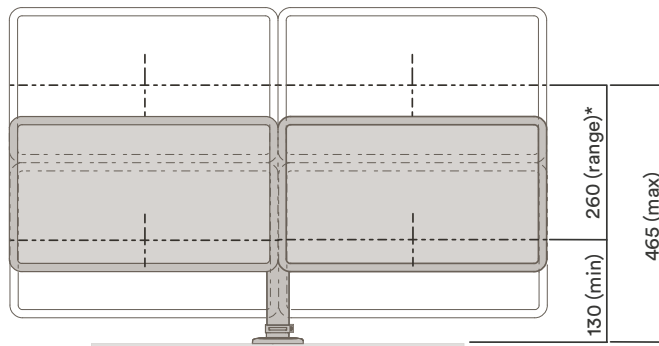
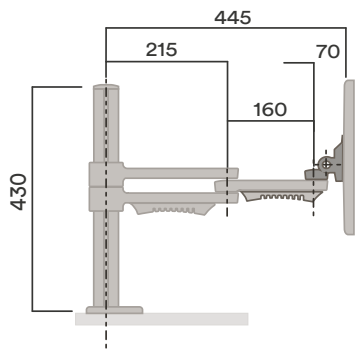
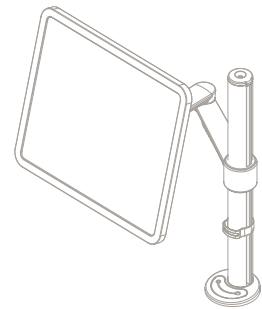
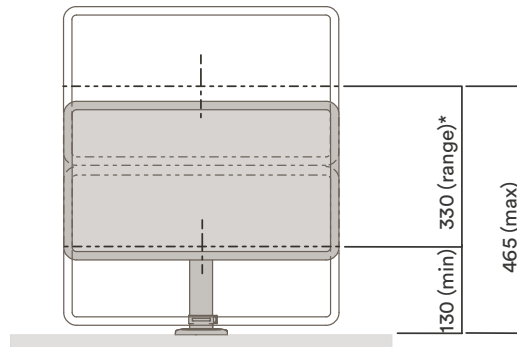
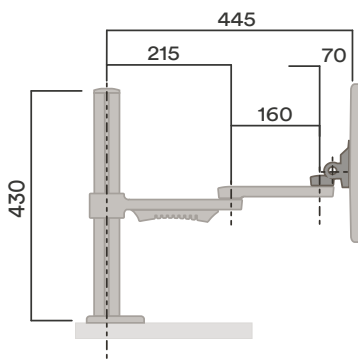

CLAMP OPTIONS

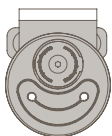

DESK CLAMP



BOLT THROUGH

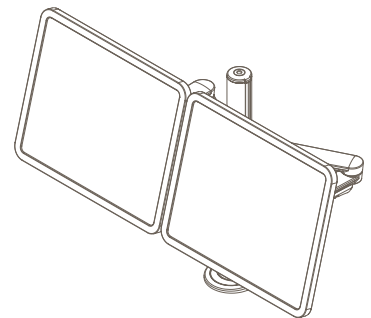

Watts Commercial Furniture

350a Edgar St
 Bankstown NSW 2200
 PO Box 275 Condell Park 2200
 ABN: 54 064 557 893

p: 02 9771 3966
 wcf.com.au
 sales.watts@wcf.com.au
 accounts.watts@wcf.com.au

Watts Commercial Furniture reserves the right to change any or all details without prior notice. Every effort has been made to ensure the information is accurate at the time of printing.

September 2022

C.ME.

Please refer to a physical sample.
 Images are for an indicative reference only.
 Actual product may vary slightly, depending upon model configurations.

EXTENDED POST HEIGHT

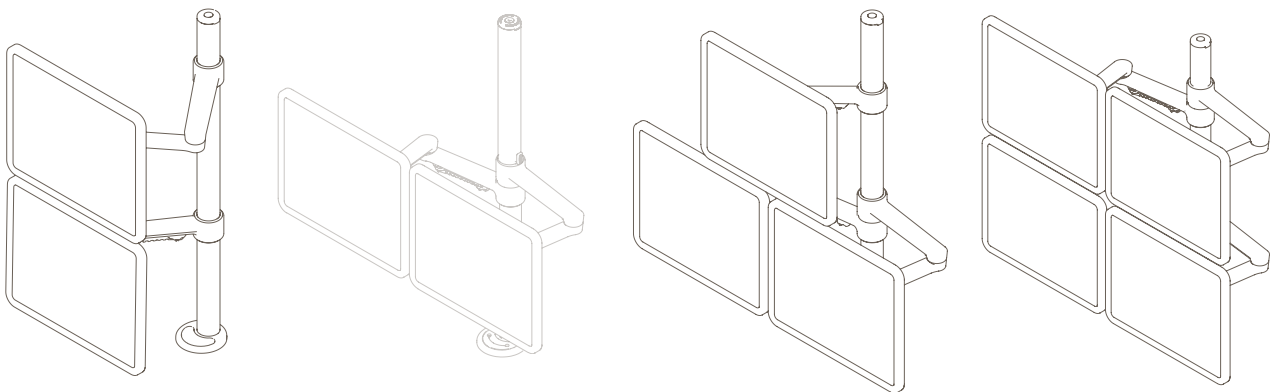
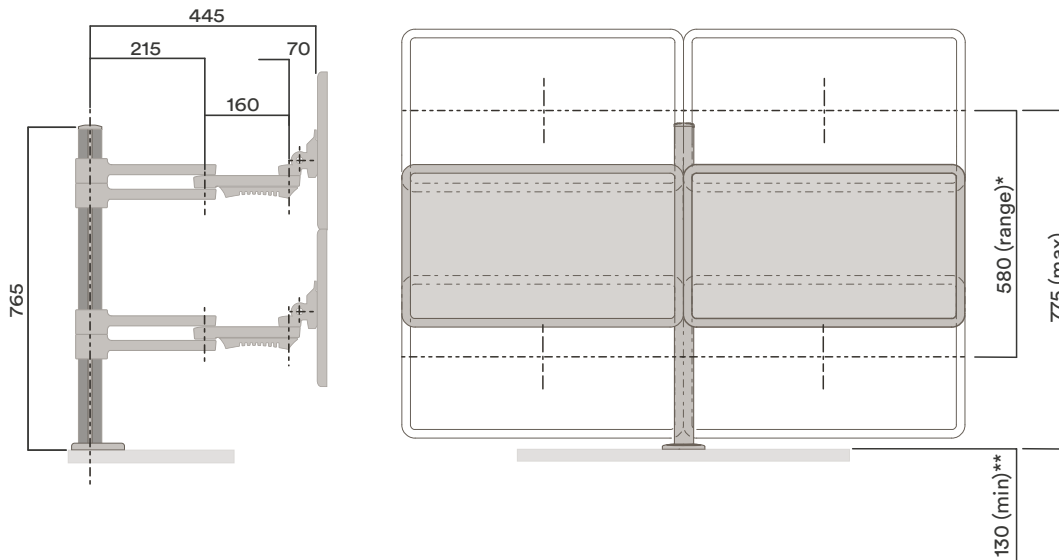

CLAMP OPTIONS

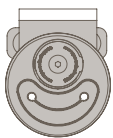

**DESK
CLAMP**



**BOLT
THROUGH**

Watts Commercial Furniture

350a Edgar St
 Bankstown NSW 2200
 PO Box 275 Condell Park 2200
 ABN: 54 064 557 893

p: 02 9771 3966
 wcf.com.au
 sales.watts@wcf.com.au
 accounts.watts@wcf.com.au

Watts Commercial Furniture reserves the right to change any or all details without prior notice. Every effort has been made to ensure the information is accurate at the time of printing.

September 2022

Accessories.

Please refer to a physical sample.
Images are for an indicative reference only.
Actual product may vary slightly, depending upon model configurations.

LAPTOP TRAY

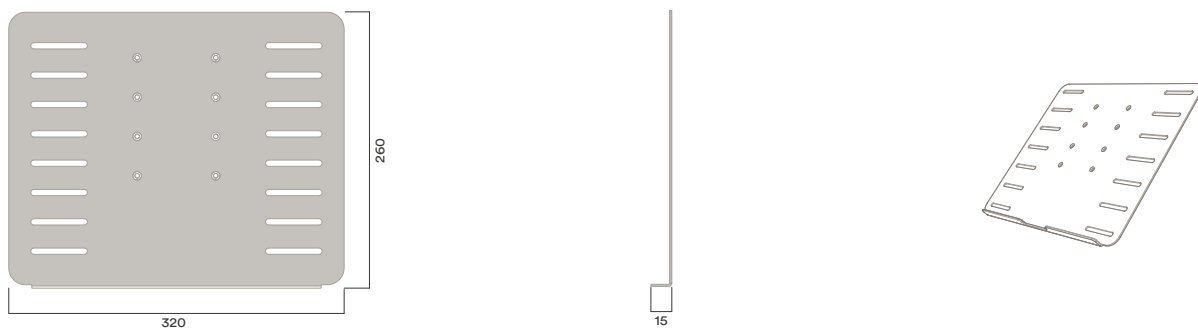

C.ME MONITOR ARM ROTATION LIMITER KIT

